

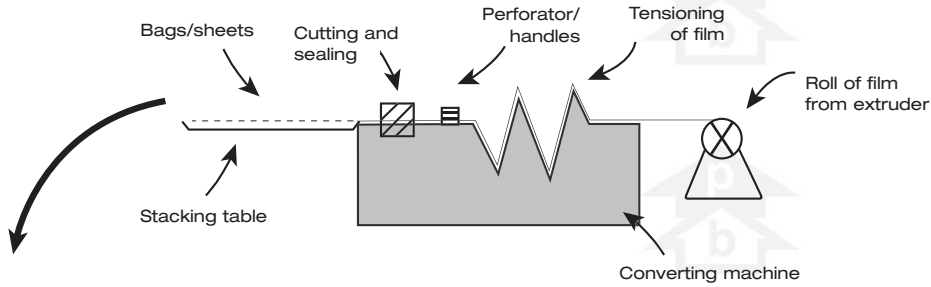

Polybags Limited

Lyon Way, Greenford,
Middlesex UB6 0AQ
t. 020 8575 8200
f. 020 8578 2247
www.polybags.co.uk

POLYBAGS BAG PRODUCT SHEET



PRODUCT TYPES

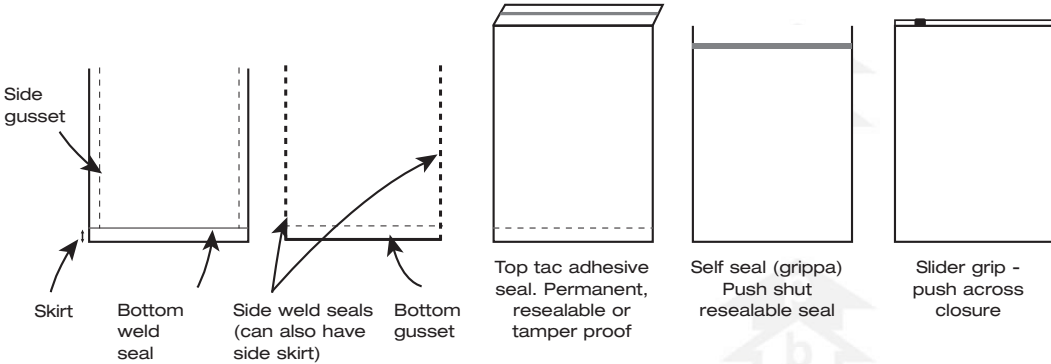

AVAILABLE HANDLES AND ADDITIONS

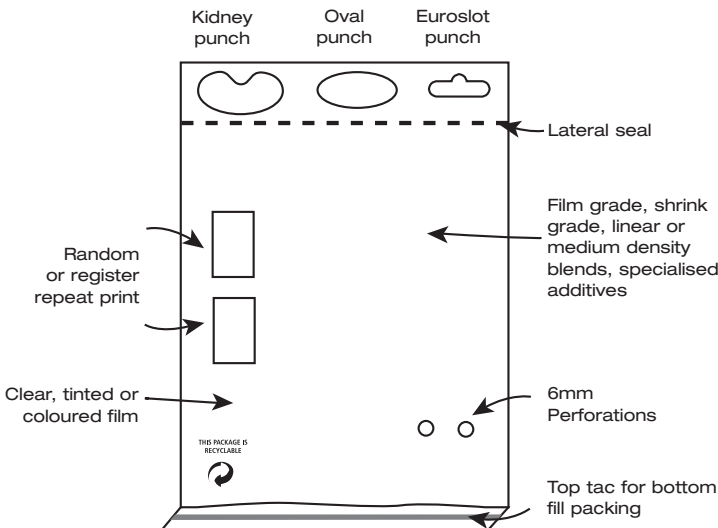

CONSIDERATIONS WHEN BUYING BAGS

Larger quantities can give substantial savings due to set up costs. Side weld bags are normally cheaper to produce than end weld bags but are not quite as strong.

Adding print in register involves more cost than a random repeat print.

Bags can be boxed as you require but individual boxes must be under 20kg. Lined boxes and special packing facilities are also available.



Polybags Limited

Lyon Way, Greenford,
Middlesex UB6 0AQ
t. 020 8575 8200
f. 020 8578 2247
www.polybags.co.uk

POLYBAGS FILM PRODUCT SHEET

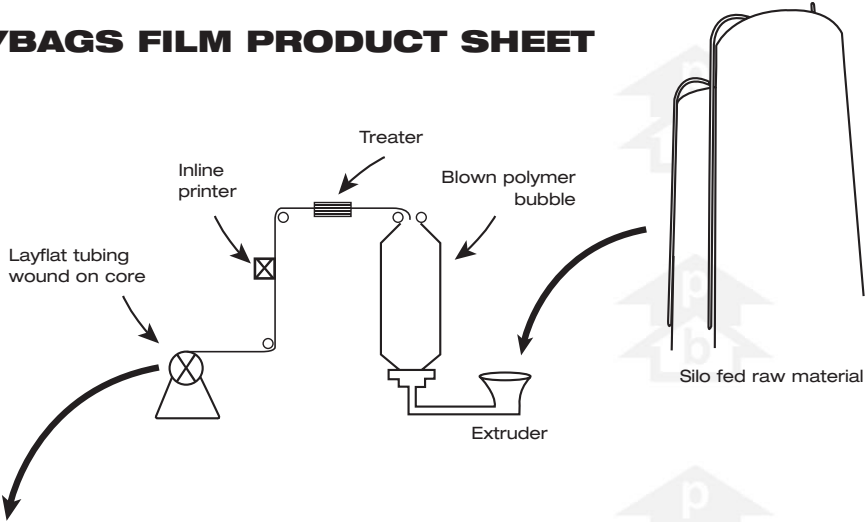

PRODUCT TYPES

Layflat Tubing (LFT)

Polythene bubble collapsed and wound up forming a tube. Can be GUSSETTED at sides (so the bubble opens out to a larger width)

- Laundry/Garment covers
- Packing then heat sealing products - posters, blinds, electrical etc



Centrefold sheeting (CFS)

Layflat tubing slit on one side before winding so that a long sheet is formed, that then opens out to twice the film width

- Builders rolls for protective sheeting



Sheeting

Layflat tubing slit on both sides, creating 2 sheets on top of each other. Single wound sheeting (SWS) if wound separately. Double wound sheeting (DWS) if wound together.

- Automatic fill and seal machines
- Magazine mailing film

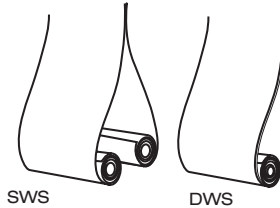

SWS

DWS

J-Fold

A strip of material is removed from the film before winding.

- To convert into bags with lips

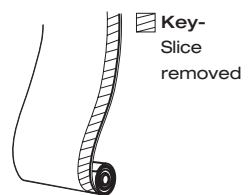

Key-Slice removed

CONSIDERATIONS WHEN BUYING FILM

Rolls of film can be as long/heavy as you require up until the point they become unstable. Rolls less than 6" wide or with narrow gussets become unstable much quicker. We will advise you on appropriate reel sizes

Rolls above 30kg have to be dispatched by pallet (or collected). Short rolls incur additional core, wrapping and time costs.

Standard cores are cardboard but plastic cores are also available. All rolls are wrapped in polythene and labelled as standard, with special packaging on request.

Film products are available in standard film grade and shrink grade as well as with blends and/or additives to order. Please note that shrink grade film for heat guns and tunnels is distinct from stretch wrap film which is a clingy material normally for wrapping around pallets.